

AF 156

Self Contained Ice Machine up to 160 kg

Item #:
Project:
Quantity:



FEATURES

- Agion: the technology that makes products cleaner and longer lasting with built-in protection working 24/7 to resist the growth of microbes and the development of unpleasant odors.
- Clean alert: advises with a blink when it's time to clean the filter.
- Electronic control: ambient and water temperatures may change throughout the years but your ice maker will stay the same.
- Front access condenser air filter: a do-it-yourself cleaning operation that saves time and money and makes your ice maker live longer.
- Water in / ice out concept (no cycles, zero water wastage): limits to almost zero excess energy, water and time wastage.
- Ergonomic access to ice with sliding disappearing door: one-touch door lift, makes barman's life significantly easier.
- Built-in storage bin: allows most undercounter installations for easier fit-in solutions.



AF 156
Flake ice
Residual water content 25%

CONDENSING SYSTEM

Air cooled
Water cooled

INTERNAL BIN CAPACITY

60 kg

REFRIGERANT GAS

R404A

OPERATING REQUIREMENTS

	Minimum	Maximum
Air temperature	10°C	43°C
Water temperature	5°C	38°C
Water pressure	1 bar (14 psi)	5 bar (70 psi)
Electrical voltage	-10%	+10%

VOLTAGE V/Hz/ph

230/50/1
230/60/1

Certifications:



IMPORTANT NOTICE:
Models and specifications are subject to change without notice. This spec sheet is meant for commercial purpose only. For technical documentation please refer to our service manuals.

Download our free App Scotsman Ice
Apple store
Google play
Windows store



www.scotsman-ice.it
www.scotsman-ice.com

Self Contained Ice Machine up to 160 kg

AF 156

Self Contained Ice Machine up to 160 kg

Item #:
Project:
Quantity:

Self Contained Ice Machine up to 160 kg

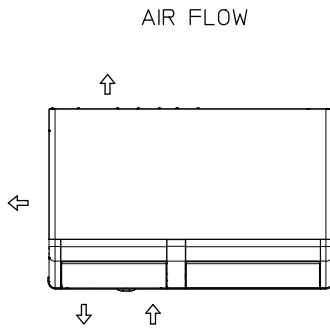
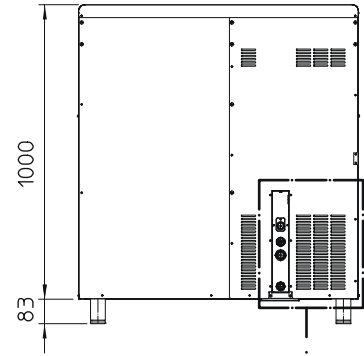
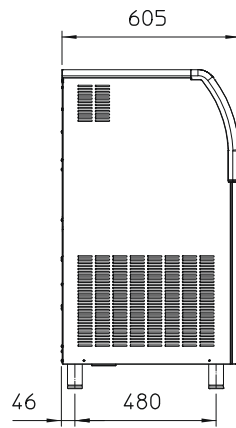
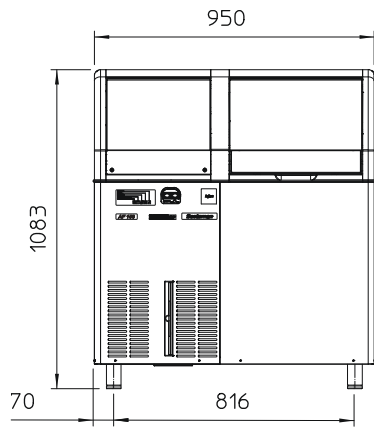

- UNIT OF MEASUREMENT: mm
- 25/32" - OVERFLOW DRAIN
 - 3/4" GAS - WATER INLET
 - 3/4" GAS - WATER OUTLET WATER COOLED UNIT ONLY
 - 3/4" GAS - WATER INLET WATER COOLED UNIT ONLY
 - CORD SET

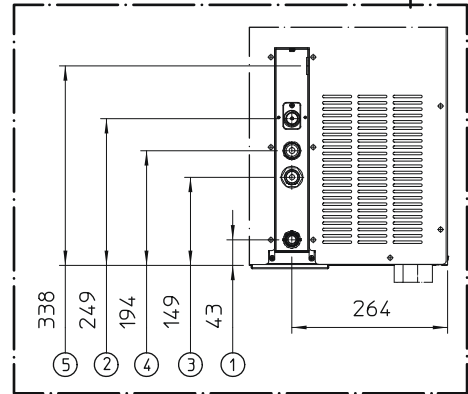

UNIT DATA			Compressor		Circuit wires		Max. fuse size		
			Version	Voltage	Btu/h	W	No.	Ømm ²	A
Size (W x D x H)	950 x 605 x 1083 mm		AF 156 AS	230/50/1	4845	1420	3	1.5	10
Net weight	75 kg		AF 156 WS	230/50/1	4845	1420	3	1.5	10
SHIPPING DATA			AF 156 AS	230/60/1	4845	1420	3	1.5	10
			AF 156 WS	230/60/1	4845	1420	3	1.5	10
Carton (W x D x H)	1030 x 680 x 1170 mm								
Weight	88 kg								
			24 h ice production kg °C Amb. / °C Water			Energy consumption*		Water usage*	Instant power
Version	Condensation	Voltage	10°C/10°C	21°C/10°C	32°C/21°C	kWh/100 kg	kWh/24h	l/h	W
AF 156 AS	Air	230/50/1	150	148	120	11.5	13.8	5.0	575
AF 156 WS	Water	230/50/1	160	156	140	9.0	12.5	5.4	510
AF 156 AS	Air	230/60/1	150	148	120	11.5	13.8	5.0	575
AF 156 WS	Water	230/60/1	160	156	140	9.0	12.5	5.4	510

(*) Data refer to 32°C Amb. / 21°C Water temperature conditions